

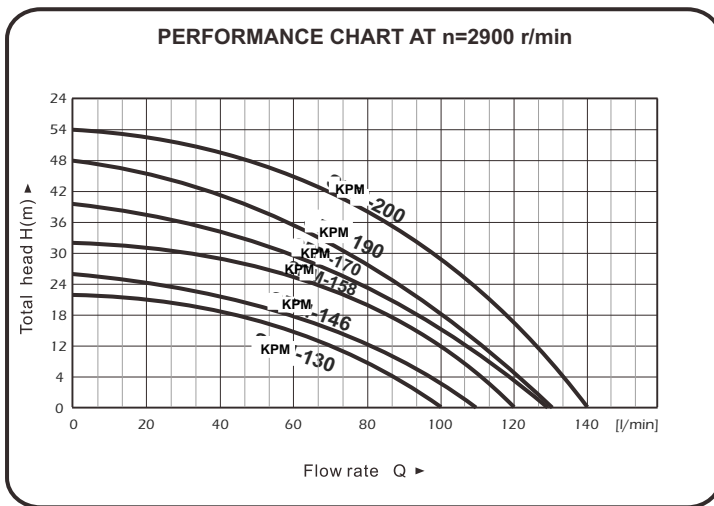

KPM Series Centrifugal Pumps, 50Hz



OPERATING CONDITIONS

Max. suction head	7 m
Max. liquid temperature	40 °C
Max. ambient temperature	40 °C
Max. working pressure	6 Bar

CE  IP44

FEATURES

- Single suction centrifugal pump, with high efficiency.
- Copper impeller, stable performance.
- High head, small flow rate.

APPLICATION

- Suitable for transfer water without abrasive particles or other liquid whose properties are similar to water.
- Widely used in vegetable greenhouse water supply, breeding industry water supply and drainage, water tower water supply, pipeline pressurization, various corollary equipment, etc.

SPECIFICATION

Model	Power [HP]	Power [kW]	Max. Flow [m ³ /h]	Max. Head [m]	Suction [Inch]	Discharge [Inch]	Weight [kg]	Packing Dim. [mm]
KPM-130	0.5	0.37	6	22	1"	1"	8.5	280x185x230
KPM-146	0.75	0.55	6.6	26	1"	1"	11.5	340x210x265
KPM-158	1	0.75	7.2	32	1"	1"	13.5	340x210x265
KPM-170	1.5	1.1	7.8	40	1.25"	1"	20	390x240x290
KPM-190	2	1.5	7.8	48	1"	1"	23	390x260x320
KPM-200	3	2.2	8.4	54	1"	1"	30.5	455x280x340

MOTOR

- Single-Phase 220V/50Hz.
- Mechanical seal: Ceramic/Graphite/NBR rubber
- Motor: 2Pole asynchronous motor, copper wires, built-in thermal protector, fully closed fan cooling, continuous running.
- Protection: IP44
- Insulation: Class B

PUMP DIMENSIONS

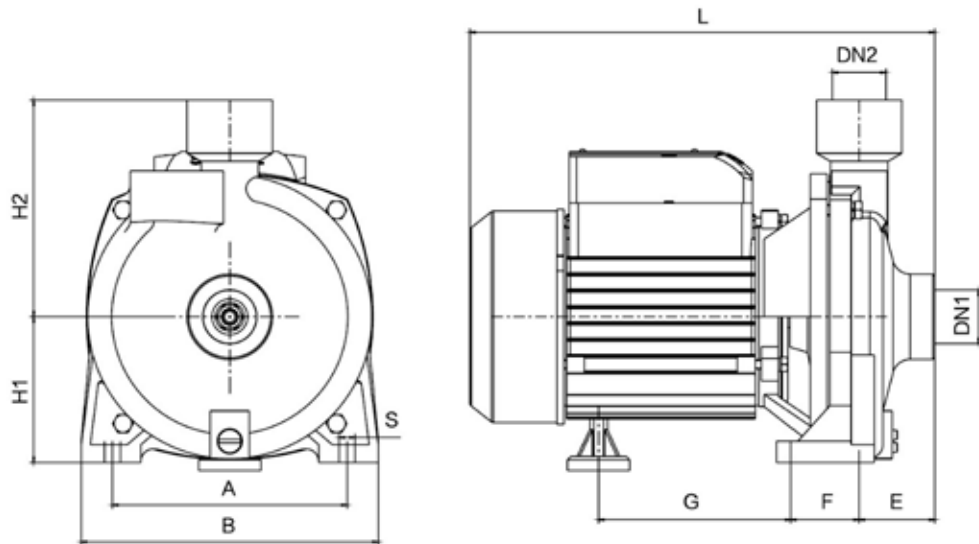

Model	DN1 [Inch]	DN2 [Inch]	Dimensions [mm]									Weight [kg]
			A	B	E	F	G	L	S	H1	H2	
KPM-130	1"	1"	132	167	42.5	38.5	108	262	9	82	122	8.5
KPM-146	1"	1"	144	175	47	38	132	296	10	94.5	130.5	11.5
KPM-158	1"	1"	158	192	45	42	134	300	10	100	144	13.5
KPM-170	1.25"	1"	170	210	46	45.5	164.5	346	11	108	153	20
KPM-190	1"	1"	185	230	36	37	171	351	10	116	177	23
KPM-200	1"	1"	185	230	54	37	197	401	10	116	177	30.5