

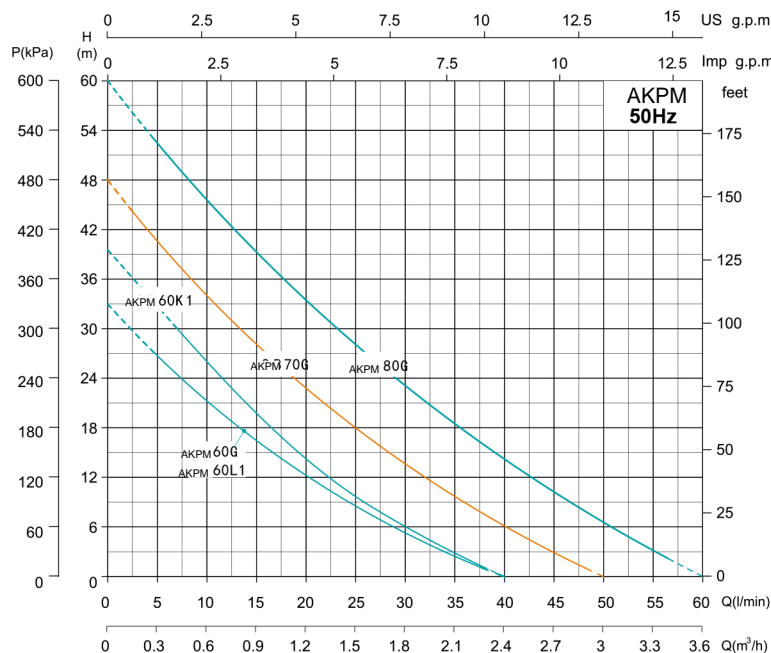

AKPM Series

Monoblock Centrifugal Pump



OPERATING CONDITIONS

Max. fluid temperature 60°C
 Max. ambient temperature 40°C
 Max. suction lift 8m

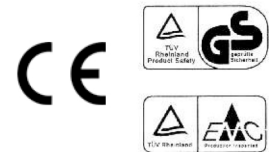

Model	Power		Max. Flow (m³/h)	Max. Head (m)	Head Range (m)	Max. Suction (m)
	kW	HP				
Single-Phase						
AKPM60G	0.37	0.5	2.4	33	1~27	8
AKPM70G	0.55	0.75	3	48	1.5~44	8
AKPM80G	0.75	1	3.6	60	2.5~53	8
AKPM60L1	0.37	0.5	2.4	33	1~27	8
AKPM60K1	0.37	0.5	2.4	40	1.5~30	8

Note: The length of cable is 0.3M, no plug.

- Pump body Cast iron
- Impeller Brass
- Mechanical seal Ceramic and graphite
- Motor asynchronous, high efficiency induction motor
- Insulation Class B
- The thermal protection relay (motor protector) is incorporated in single phase motors.
- Three phase motors require an adequate motor protector, with connections according to current standards.
- radial blades impeller
- reliable and robust construction
- easy to use
- for clean water without particles
- for garden sprinkle ring
- for boosting water applications etc.
- installed in a covered, dry place
- high tolerance of the presence of entrained air in the fluid to the pumped.

Parts and materials

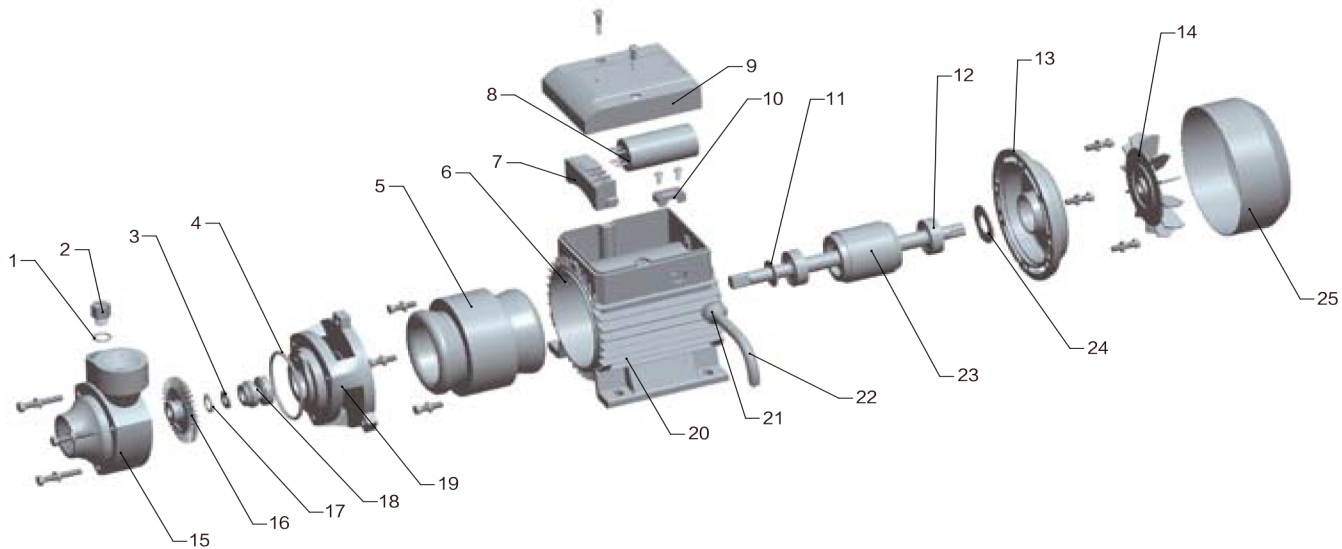

No.	Component	No.	Component	No.	Component
1	O-ring	10	Cable Control Cover	19	Coupling
2	Air Faucet	11	Waterproof Ring	20	Motor Case
3	Washer	12	Bearing	21	Cable Sleeve
4	O-ring	13	End Cover	22	Cable
5	Stator	14	Fan	23	Rotor
6	Motor Housing	15	Pump Body	24	Wave Spring
7	Terminal Board	16	Impeller	25	Fan Cover
8	Capacitor	17	Shaft Circlip		
9	Terminal Block Cover	18	Mechanical Seal		

NO.	Model	QB60G	QB60L1	QB60K1	QB70G	QB80G
8	Capacitor(μ F)	8 μ F/450V	10 μ F/450V	10 μ F/450V	12 μ F/450V	15 μ F/450V
12	Bearing	6201-2RZ			6202-2RZ	
	Motor Shaft	Steel 45#				
18	Mechanical Seal	103-12/20.5 B:A(P)			301-12/21 B:A (P)	
		A:Graphite B: Ceramic P: NBR				
20	Motor Case	Aluminum				
19	Coupling	Cast iron				
15	Pump Body	Cast iron				
16	Impeller	Brass				

Dimensions

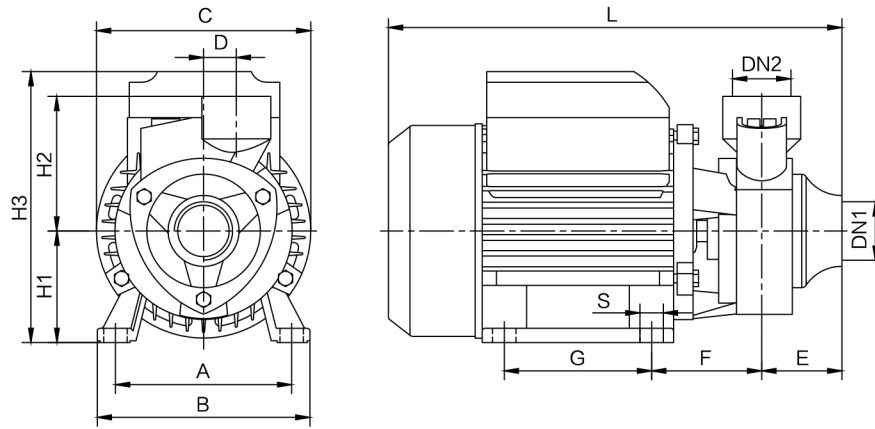

Model	DN1	DN2	Dim.(mm)											N.W. (kg)	
			A	B	C	D	E	F	G	L	S	H1	H2		H3
Single-Phase	(Inch)														
AKPM60G	1	1	100	120	121	16	45	64	80	258	7	63	75	150	4.8
AKPM60L1	1	1	93	115	115	15	33.5	64	58	223	7	60	68	148	4.0
AKPM60K1	1	1	93	115	115	15	33.5	64.5	58	223.5	7	60	68	148	4.4
AKPM70G	1	1	112	137	137	18	49.5	78.5	88	294	7	72	85	181	8
AKPM80G	1	1	112	137	137	20	60	80	88	305	7	72	84.5	181	9.5